

**SERVICE
MANUAL**

**FI06.6 / FI06.6A
FI56.6 / FI56.6A**

Grader

Print No. 87726937A



SERVICE MANUAL

FI06.6 / FI06.6A / FI56.6 / FI56.6A
Grader

Print No. 87726937A



CNH Baumaschinen GmbH

Product documentation

Staakener Str. 53 - 63

13581 Berlin

Tel.: +49 (0)30 3399 443

FAX: +49 (0)30 3399 201

TO THE READER

This repair manual is intended for **professional repair technicians**. It contains important information, needed for carrying out specialised repair work.

Please read carefully through the **repair manual**, and also the operating instructions, before undertaking any repair work.

Use the **repair manual**, but also use the **operating instructions** and **parts catalogue** for reference and guidance, even if you are already familiar with the technology used in graders.

The repair manual will allow the experienced construction machine mechanic to carry out the necessary repair work correctly.

USE

The repair manual describes the machine model in the form it was originally delivered. It does not describe any implements and modifications that maybe added later.

The repair manual contains the following information:

- Safety instructions
- Technical data and special tools
- Function description
- Performance test
- Troubleshooting and fault correction
- Repair instructions

The **Safety Instructions** section describes the recommended procedures for preventing the risk of injuries to the operator and the personnel responsible for maintaining and working on the machine.

The **Specifications** section contains service data, conversion tables and lists of special tools and maintenance materials required. The other sections contain the following information for each

mechanical assembly:

- technical description and information regarding the operation of essential systems and equipment;
- information about performance tests on the machine;
- troubleshooting and information for identifying faults on the machine;
- technical information necessary for repair operations on the machine, the equipment necessary for carrying out repairs, information about maintenance standards, procedures for removal/installation and for disassembly/assembly.

You can use the list of contents to find the necessary information easily.

The illustrations are partially simplified to make them more easily understood.

Although it may result in apparent differences with your particular grader model, this is intended to make the information clearer.

REPAIR

Carry out the required repair operations as soon as possible. Doing so will reduce repair costs and increase the availability of your grader.

In all repair operations, always follow the instructions in the workshop manual and the operating instructions. Customer Service will be pleased to carry out for you any extensive operations not described in the workshop manual.

Always use only **original replacement parts**.

FURTHER REFERENCE MATERIAL

In addition to the present manual, please also refer to the following documentation:

- Operating instructions
- Parts catalogue

NOTES:

SAFETY INSTRUCTIONS	0
SPECIFICATIONS	1
ENGINE	2
TRANSMISSION	3
REAR AXLE	4
FRONT AXLE	5
EQUIPMENT	6
HYDRAULIC SYSTEM	7
BRAKE SYSTEM	8
STEERING SYSTEM	9
ELECTRICAL SYSTEM	10
CAB AND OPERATING PLATFORM	11

Section

0

SAFETY INSTRUCTIONS



PARAGRAPH 0

LIST OF CONTENTS

1	BASIC SAFETY INFORMATION	0-3
1.1	Warning notes and symbols	0-3
1.2	Correct use	0-3
1.3	Organizational procedures	0-4
1.4	Personnel selection and qualifications - basic responsibilities	0-5
1.5	Safety information for specific phases of operation	0-6
1.6	Special operations when using the machine, servicing and fault repair work as part of working procedure, waste disposal	0-7
1.7	Notes on special types of hazard	0-9
1.7.1	Electrical energy	0-9
1.7.2	Gas, dust, vapour, smoke	0-9
1.7.3	Hydraulic, pneumatic system	0-9
1.7.4	Noise	0-9
1.7.5	Oil, grease and other chemical substances	0-9
1.8	Transport, towing and restarting	0-10
2	WARNING AND INSTRUCTION PLATES	0-12
2.1	Left side of vehicle	0-12
2.2	Right side of vehicle	0-14
3	OPERATION	0-17
3.1	General Remarks	0-17
3.2	Fuelling	0-19
3.3	Fuelling system (optional)	0-20
3.4	Driving	0-21
3.5	Towing /recovery	0-23
3.5.1	Towing devices	0-23
3.5.2	Transport	0-23
3.5.3	Crane loading	0-23
3.6	Everyday operation	0-24
3.7	Using the grader	0-24
3.8	Working equipment	0-25
3.9	SECURING THE MACHINE	0-26
4	INSPECTION AND MAINTENANCE	0-27
4.1	General information	0-27
4.2	Fuel system	0-31
4.3	Electrical system	0-32
4.4	Power shift transmission	0-33
4.5	Hydraulic system	0-33
4.6	Brakes	0-34
4.7	Wheels and tyres	0-35
4.8	Air conditioning system (optional)	0-37
4.9	Repair	0-38
5	PROTECTING ELECTRONIC UNITS WHEN WELDING	0-40
5.1	Disconnect the connectors of the electronic equipment	0-40
5.1.1	Transmission control 'EST37A' (XA1) and front wheel drive control 'FWD' (XA8.1)	0-40
5.1.2	AIC connections	0-41

5.1.3	Engine control	0-41
5.1.4	Cab connectors	0-41
5.1.5	Alternator connector	0-42
6	VACUUM PUMP	0-43
6.1	General information	0-43
6.2	Package content	0-43
6.3	Vacuum pump connection	0-43

1 BASIC SAFETY INFORMATION

1.1 Warning notes and symbols

The following symbols are used in the operating instructions to indicate particularly important information:

CAUTION: *Safety rules and procedures, designed to protect the driver and others from mortal dangers or injuries, and to prevent serious damage to property.*

NOTE: *Notes and precautions to avoid damage to machinery and property.*

1.2 Correct use

This machine is constructed according to the recognized mechanical safety regulations, and using state-of-the-art technology. Nevertheless, when in operation, situations can occur that present serious or mortal dangers to the operator and third parties, or which could cause damage to the machine and other property.

The machine should be used only if it is in proper operating condition, and only by operators who are aware of the dangers, know the safety procedures, and have read the operating instructions! The important notes are placed at the start of this section. Immediately repair any faults (or have them repaired) if these could have a prejudicial effect on safety.

This Grader is principally designed for:

- Creating a double course
- Clearing top soils
- Scarifying old road surfaces and hard ground
- Cutting embankments
- Clearing ice and snow
- Placing, spreading, mixing, and compressing materials.

The Grader can also be used in conjunction with other operating equipment for special applications. The Technical Data provide clear information on this subject.

Proper use of the machine also means following the operating instructions and applying the inspection and maintenance conditions.

Using the grader for any other purpose, for example:

- transporting personnel,
- as a working platform,
- towing or carrying loads without attaching the proper working attachments, is considered improper use.

Improper use of the machine can pose mortal danger to operating personnel or other persons, or may result in physical injuries, or may cause damage to property.

The manufacturer, supplier will not be liable for any damage resulting from improper use. In this case, the user alone will be responsible.

Noise emission data as stated in statutory order 3 pursuant to the mechanical safety law of 18/01/1991 or EC machinery guideline 89/392/EWG.

Using the earth-moving equipment properly, with ISO 7096 standard driver seats, will ensure that the measured vibration frequencies (measured as described in ISO 2631 Part 1) meet the requirements regarding protection from whole-body vibrations.

1.3 Organizational procedures

Keep the operating instructions stored at the location where the machine is used, and in a place where they can be easily accessed, for example in the holder provided!

In addition to the operating instructions, follow and draw attention to the general legal regulations and other obligatory requirements regarding accident prevention and environmental protection!

These requirements may, for example, concern the handling of dangerous goods, the making available / wearing of personal protective equipment or highway code regulations.

Supplement the operating instructions with additional instructions, including supervisory and reporting duties, in order to take account of specific operating conditions, for example, Particular work plans, working processes or personnel.

Before starting work, personnel appointed to carry out work on the machine must have read the operating instructions, and particularly the Safety Information section. It will be too late to do this when the actual work has begun. This especially applies to personnel employed occasionally, for example, for setting up or maintaining the machine.

You must at least check occasionally that personnel can demonstrate safety and risk awareness when working!

Loose or long hair must be tied up, and personnel must not wear loose clothing or jewellery, including rings. These are a potential risk, for example, if they are caught up or pulled in by machinery.

Where necessary, or when specified by the regulations, personal protective equipment must be worn!

Pay attention to the safety information and warning notices on the machine!

Check that all safety information and warning notices at or on the machine remain fully and clearly legible.

If there are any changes that affect safety or the operating behaviour of the machine, stop the machine immediately and inform the person or department responsible.

Modifications, conversions or retrofits that might affect safety must not be made to the machine without the approval of the supplier! This also applies to the installation or re-adjustment of safety devices and valves, or welding work on load-bearing parts.

Replacement parts must meet the technical requirements stated by the manufacturer. This can be ensured by always using original replacement parts.

Replace hydraulic hoses at the proper times or at the stated intervals, even if no defects affecting safety are visible!

For the periodic checks / inspections, keep to the specified intervals or the times specified in the operating instructions.

When maintenance work is being carried out, fire extinguishers and their operating instructions must be displayed at a suitable place!

Pay attention to fire detection and firefighting devices.

1.4 Personnel selection and qualifications - basic responsibilities

Only trained and reliable personnel should be allowed to work on or with the machine. Apply the minimum age required by law.

Only use personnel who have been suitably trained or instructed, and clearly set out the responsibilities assigned for operating, setting up, maintenance, and repair!

Ensure that only the personnel appointed for the task concerned is allowed to work on or with the machine!

Define the responsibilities of the driver (also in relation to highway code regulations) and authorize him/her to reject third-party instructions that would lead to a breach of safety regulations.

Personnel being trained, instructed or briefed, or persons undergoing general training, must only be allowed to work on or with the machine if they are given constant supervision by an experienced person!

Work on the machine's electrical equipment should only be carried out by a qualified electrician, or a trained technician under the supervision and guidance of a qualified electrician, in accordance with the electrical regulations.

Work on the chassis, on the brake and steering systems should only be carried out by personnel trained for this purpose!

Only personnel with the necessary skills and experience should be allowed to work on the hydraulic systems.

1.5 Safety information for specific phases of operation

Normal operation

Refrain from any working methods that might be prejudicial to safety!

Before starting work, familiarize yourself with the particular working environment at the location concerned. Working environment includes, for example, obstacles in the working/traffic area, load-bearing capacity of the ground, and safety barriers necessary at the worksite relative to public traffic areas.

Take steps to ensure that the machine is only operated when in a safe and operative condition!

Only operate the machine if all safety devices and safety-related systems, for example, removable safeguards, emergency shut-off devices, noise insulation, extractor systems, are present and in operative condition.

The machine must be inspected at least once in each shift for visible damage and defects! Any changes that occur (including changes in operational behaviour) must be reported immediately to the department or person responsible! If necessary, stop the machine immediately and secure it.

If there is a malfunction, stop the machine immediately and secure it! Faults must be repaired immediately!

Start the machine only from the driver's position.

Follow the operating instructions, during the switch-on/switch-off procedures.

Before starting up the machine, ensure that no one will be put at risk by when the machine is started!

Before starting work / driving, check whether the brake, steering, lighting and signalling systems are operational.

Before moving off, always check that attachments are secured to prevent accidents!

If using public roads, streets, or other areas, follow the regulations in the highway code and, if necessary, make the machine road-worthy as required by the highway code before doing so.

In conditions of poor visibility or when dark, always switch on the vehicle lights!

Passengers should only sit in the passenger seats provided for this purpose.

When passing through underpasses, bridges, tunnels, under overhead lines, etc., always check that there is sufficient headroom!

Always keep at a sufficient distance from the edges of trenches and embankments.

Do not use any working methods that might endanger the stability of the machine!

Do not drive with overhead attachments positioned in a transverse direction; always drive with attachments and loads lowered and near the ground, especially when driving uphill/downhill!

When on a gradient, always adapt vehicle speed to the particular conditions! Always change to the lowered position in advance of the gradient, never while driving on it!

Before leaving the driver's seat, always immobilise the machine to prevent it moving off accidentally, and to prevent access by unauthorized persons. Switch off the engine!

1.6 Special operations when using the machine, servicing and fault repair work as part of working procedure, waste disposal

For assembly work carried out above body height, use the appropriate safety hoists and work platforms provided for this purpose.

Do not use machine parts as hoists!

Apply the intervals specified in the operating instructions for adjustment, maintenance, and inspection tasks, and pay attention to the replacement data for parts and components. These tasks should only be carried out by qualified personnel!

Inform the operating personnel before starting special or repair operations! Appoint supervisors.

When carrying out any tasks related to the operating, retrofitting or adjusting of the machine and its safety devices, and to maintenance, inspection or repair work, follow the switch-on/switch-off procedures described in the operating instructions and the notes concerning repair operations.

Whenever required, seal off the repair area, leaving plenty of room!

If the machine is switched off completely for maintenance and repair work, it must be secured to prevent it being switched on accidentally:

- Take out the key and
- attach a warning sign.

Only carry out maintenance and repair work when the machine is parked on a level, sufficiently load-bearing surface and secured to prevent it moving off or collapsing!

When being replaced, individual components and major assemblies should be carefully fastened and secured to the lifting gear. Only use suitable and correctly functioning lifting gear, and load-handling equipment with sufficient carrying capacity. Do not stand or work under suspended loads!

Only appoint experienced persons to attach loads and instruct crane drivers! The instructor must stand where they are visible to the operator, or be in contact with him by voice communications.

For maintenance work at greater heights, wear fall-protection!

Keep all handles, steps, guard rails, landings, platforms and ladders clear of dirt, snow and ice!

At the start of maintenance/repair work, clean any oil, fuel, or operating fluids from the machine, and particularly from screw connections or other connections. Do not use aggressive cleaning agents! Use fibre-free cleaning cloths!

If cleaning the machine using water or a steam jet (high-pressure cleaner) or other cleaning equipment, seal off or cover all openings where water/steam/cleaning agents should not be allowed to enter for safety or functional reasons. Electric motors and switching cabinets are particularly at risk.

When carrying out cleaning work, ensure that heat sensors connected to fire detection and extinguishing systems cannot come into contact with hot cleaning fluids. These might trigger the fire extinguishing system.

After cleaning, remove all covers and sealing plugs completely!

After cleaning all fuel, engine oil, brake fluid, and hydraulic fluid pipes, examine them for leaks, loose connections, chafe marks and damage! Repair any defects immediately!

When carrying out maintenance and repair work, always tighten any loose screw connections.

If safety devices have to be removed for setting-up, maintenance and repair work, these should be replaced immediately and inspected when the maintenance/repair work is completed.

Dispose of operating fluids, auxiliary products and replacement parts safely, and without damage to the environment!

1.7 Notes on special types of hazard

1.7.1 Electrical energy

Use only original fuses with the correct current rating! Switch the machine off immediately if there are faults in the electrical system.

Keep the machine at a sufficient distance from overhead power lines. If working close to overhead power lines, keep the equipment away from the lines. Danger of death!

Find out the what the required safety clearances are.

If contact is made with high-voltage lines:

- Do not leave the machine.
- Drive the machine out of the danger area.
- Warn persons on the ground not to come near, or to touch the machine.
- Have the voltage switched off.
- Only leave the machine when the contacted/damaged power line has been safely de-energized.

The machine's electrical equipment should be regularly inspected. Faults such as loose connections or braised cables must be corrected immediately.

1.7.2 Gas, dust, vapour, smoke

Only operate combustion engines and fuel-driven heaters in well-ventilated areas!

If using the equipment in an enclosed space, ensure there is sufficient ventilation before starting.

Follow the local regulations applying at the worksite.

Only carry out welding, firing, or grinding work on the machine if this has been explicitly approved - risk of fire and explosions!

Before carrying out welding, firing or grinding work, clean away dust and combustible materials from the machine and its surroundings, and provide adequate ventilation (risk of explosion)!

1.7.3 Hydraulic, pneumatic system

Regularly inspect all pipes, hoses, and screw connections for leaks and visible damage. Repair any damage immediately! Spurting oil can cause burns and other injuries.

Before starting repair work, any system blocks and pressure lines (hydraulic, compressed air) that are to be opened up must first be depressurized as indicated in the descriptions of the assemblies.

Hydraulic and compressed air lines must be correctly laid and assembled. Do not get the connections mixed up!

Valves, and the length and quality of hoses must meet the requirements.

1.7.4 Noise

Noise insulation devices must be in the protection position during operation.

Wear the prescribed personal ear protection!

1.7.5 Oil, grease and other chemical substances

If handling oil, grease or other chemical substances, follow the safety instructions for the product concerned!

Be careful when handling operating fluids and auxiliary materials (risk of burns and scalds).

1.8 Transport, towing and restarting

Towing, loading and transporting should be carried out only as described in the operating instructions!

If towing, use the specified transport position, and keep to the permitted speed and distance!

Only use suitable means of transport and lifting gear, with sufficient load-carrying capacity.

When restarting, follow only the procedure described in the operating instructions.

NOTES:

2 WARNING AND INSTRUCTION PLATES

2.1 Left side of vehicle

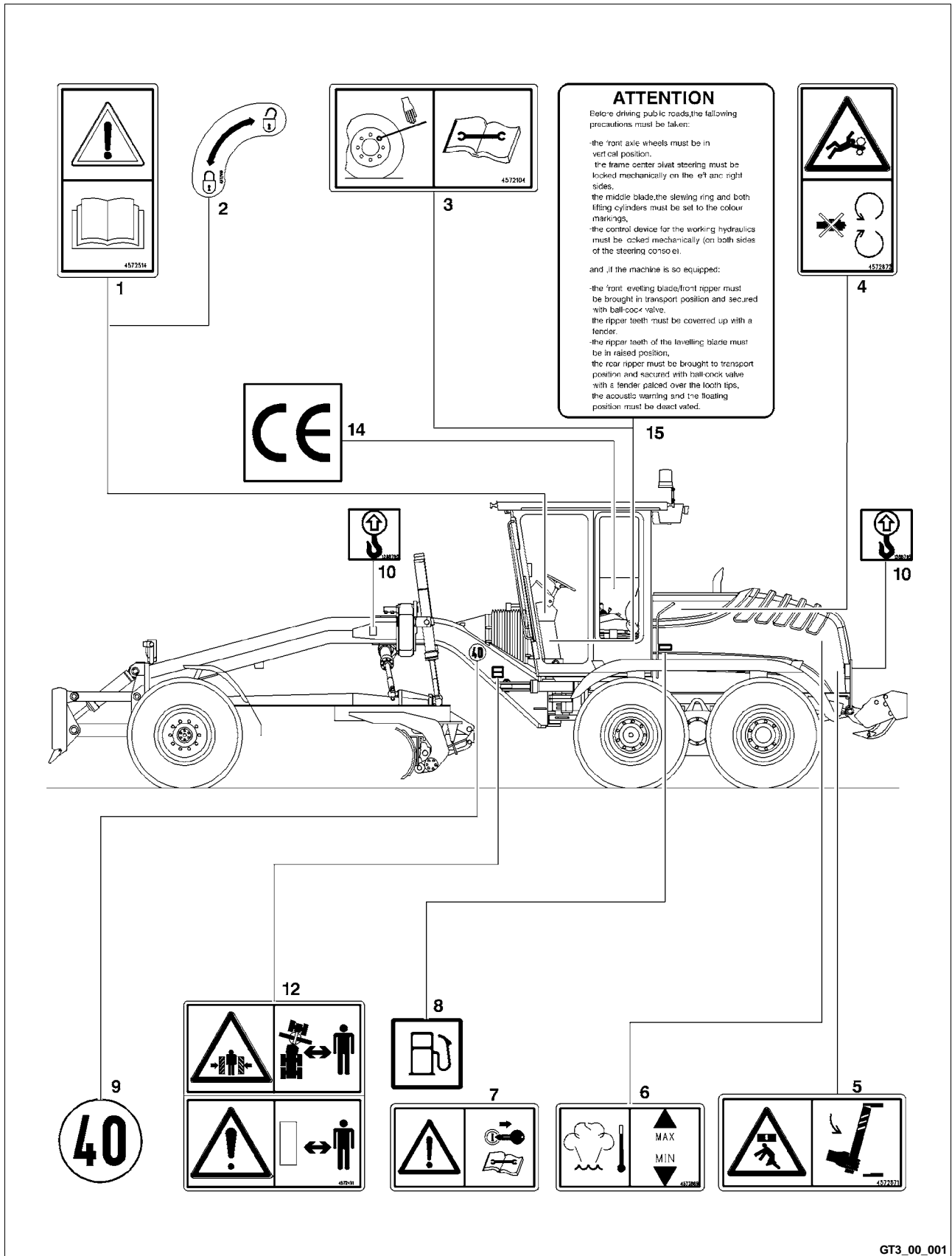

GT3_00_001

**Thanks very much for your reading,
Want to get more information,
Please click here, Then get the complete
manual**

JustClickHere 

NOTE:

**If there is no response to click on the link above,
please download the PDF document first, and then
click on it.**

**Have any questions please write to me:
admin@servicemanualperfect.com**